

**DS-2XS6K01-C36S80**  
**Solar Power Kit**

- 80 W photovoltaic panel, 360 WH chargeable lithium battery
- Support battery management, battery display, battery high-low temperature protection, charge-discharge protection, low-battery sleep protection and remote wakeup
- Water and dust resistant (IP66)

## ▪ Specification

Interface	
RS-485	1 RS-485 (half duplex, connect to Solar Power 4G Network Camera Kit )
Power Output	9~12.6 VDC, 30W max, 2 Ø5.5 mm coaxial power plugs
General	
Dimension	640.4 mm × 735.9 mm × 760 mm (25.21" × 28.97" × 29.92") (Max. size after it is completely assembled)
Package Dimension	862 mm × 352 mm × 762 mm (33.9" × 13.9" × 30")
Weight	Approx. 28.0 kg (61.7 lb.)
With Package Weight	Approx. 34.1 kg (75.2 lb.)
Battery	
Battery Type	Lithium
Capacity	360 WH (90 WH for each battery)
Battery Voltage	10.8 V
Operating Temperature	Charging: -20 °C to 45 °C (-4 °F to 113 °F) Discharging: -20 °C to 60 °C (-4 °F to 140 °F)
Battery Life	More than 500 cycles
Battery Weight	Approx. 3.3 kg (7.3 lb.)
Approval	
EMC	CE-EMC (EN 55032: 2015, EN 61000-3-2:2019, EN 61000-3-3: 2013+A1:2019, EN 50130-4: 2011+A1: 2014); RCM (AS/NZS CISPR 32: 2015); FCC (47 CFR Part 15, Subpart B); IC (ICES-003: Issue 7)
Safety	CB (IEC 62368-1:2014+A11)
Environment	CE-RoHS (2011/65/EU); WEEE (2012/19/EU); Reach (Regulation (EC) No 1907/2006)
Protection	Camera: IP66 (IEC 60529-2013) Wind resistance 12 level

## ▪ Typical Application

Hikvision products are classified into three levels according to their anti-corrosion performance. Refer to the following description to choose for your using environment.

This model has NO SPECIFIC PROTECTION.

Level	Description
Top-level protection	Hikvision products at this level are equipped for use in areas where professional anti-corrosion protection is a must. Typical application scenarios include coastlines, docks, chemical plants, and more.
Moderate protection	Hikvision products at this level are equipped for use in areas with moderate anti-corrosion demands. Typical application scenarios include coastal areas about 2 kilometers (1.24 miles) away from coastlines, as well as areas affected by acid rain.
No specific protection	Hikvision products at this level are equipped for use in areas where no specific anti-corrosion protection is needed.

▪ **Dimension**

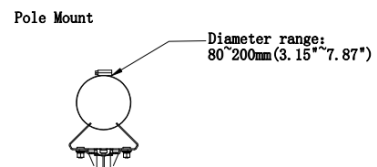
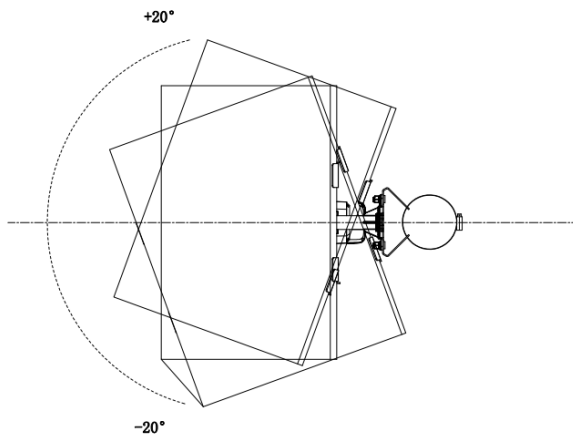
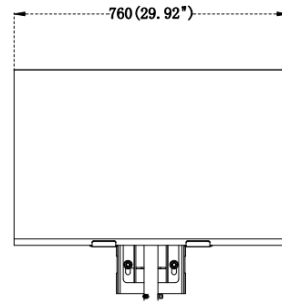
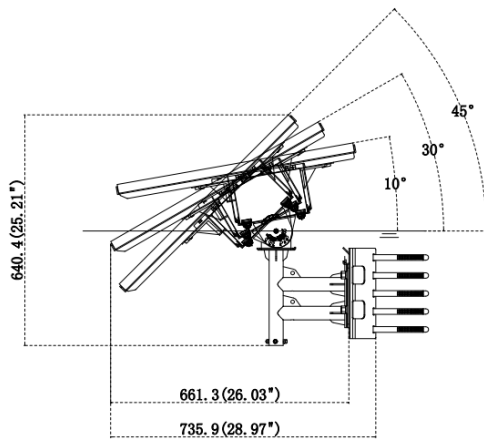

DRY

**Headquarters**

No.555 Qianmo Road, Binjiang District,  
Hangzhou 310051, China  
T +86-571-8807-5998  
www.hikvision.com



Follow us on social media to get the latest product and solution information.

